

**Tower Crane / Grue à tour / Gru a torre  
Grúa torre / Guindaste de torre**

# Turmdrehkran 100 EL

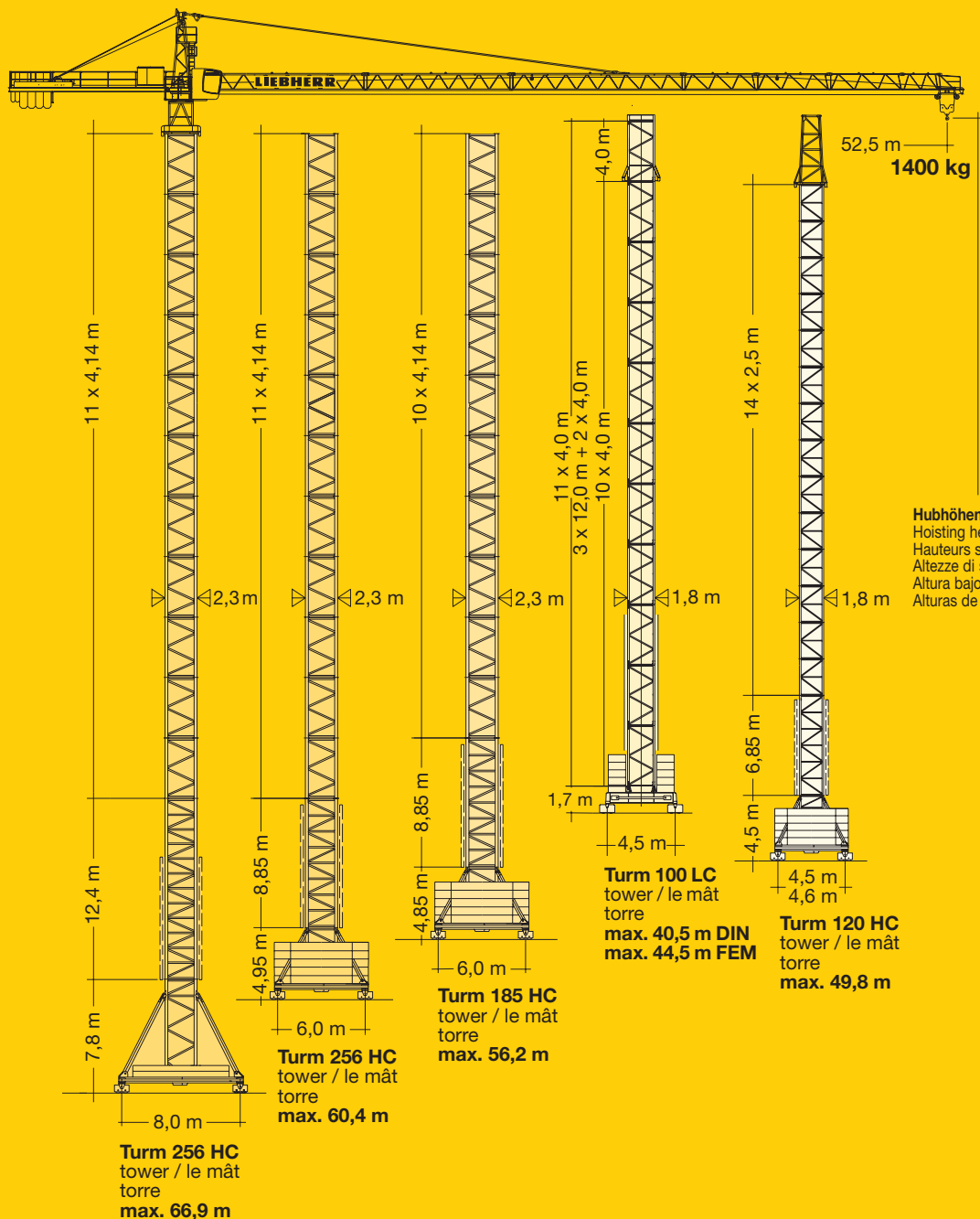

**DIN/FEM**

1 : 470

# LIEBHERR

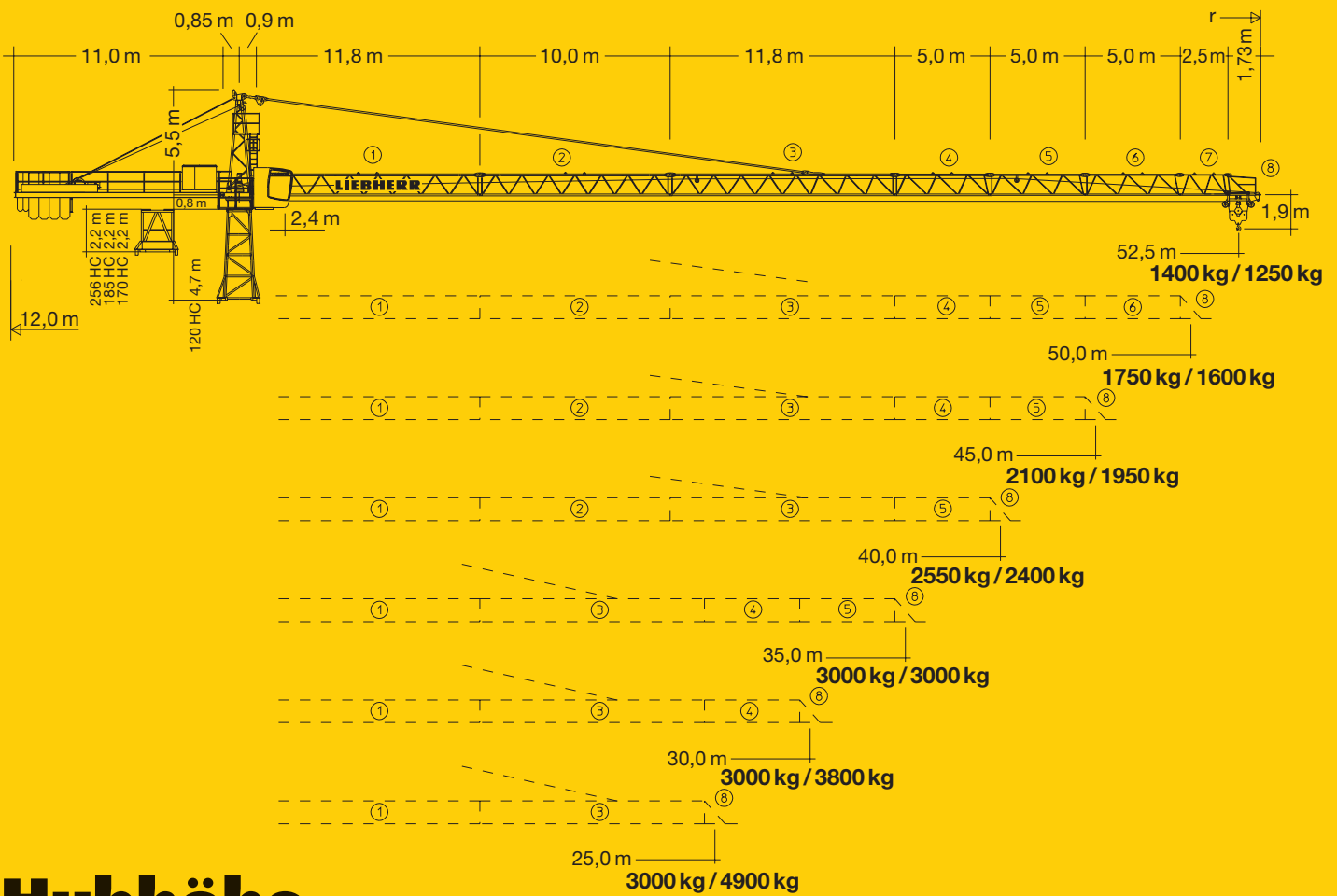

# Hubhöhe

Hoisting height / Hauteur sous crochet / Altezza di sollevamento / Altura bajo gancho / Altura de montagem

## 120 HC

14	49,8*	49,3*	45,5*	2) 4,6 m 47,0*	46,8*	46,8*
13	47,3	46,8	43,0	44,5	44,3	44,3
12	44,8	44,3	40,5	1) 3,8 m 42,0*	41,8	41,8
11	42,3	41,8	38,0	39,5	39,3	39,3
10	39,8	39,3	35,5	37,0	36,8	36,8
9	37,3	36,8	33,0	34,5	34,3	34,3
8	34,8	34,3	30,5	32,0	31,8	31,8
7	32,3	31,8	28,0	29,5	29,3	29,3
6	29,8	29,3	25,5	27,0	26,8	26,8
5	27,3	26,8	23,0	24,5	24,3	24,3
4	24,8	24,3	20,5	22,0	21,8	21,8
3	22,3	21,8	18,0	19,5	19,3	19,3
2	19,8	19,3	15,5	17,0	16,8	16,8
1	17,3	16,8	13,0	14,5	14,3	14,3
0	m 14,8	m 14,3	m 10,5	m 12,0	m 11,8	m 11,8

					
---	---	---	--	---	---

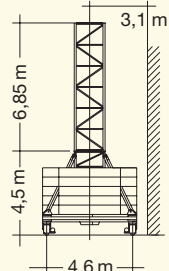
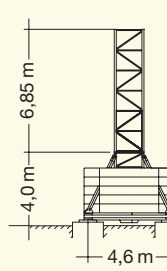
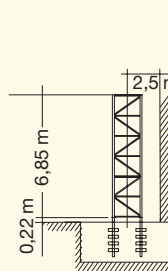
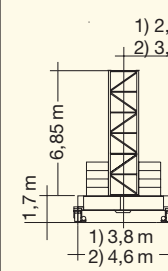
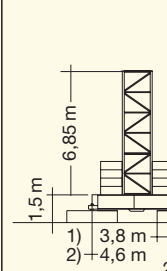
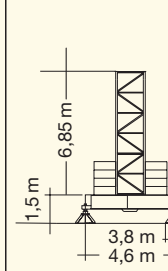
\* Weitere Hubhöhen sowie Klettern im Gebäude auf Anfrage. / Further hoist heights and climbing in the building on request.  
 Hauteurs sous crochet plus élevées et hissage dans le bâtiment sur demande. / Altre altezze di sollevamento come pure varianti di gru allungabili: su richiesta. / Para alturas bajo gancho superiores y trepado en el interior del edificio, consultar. / Outras alturas de elevação e subida no edifício: conforme ao pedido.

CD

# 100 EL

# Geschwindigkeiten

Speeds / Vitesses / Velocità / Velocidades / Velocidades

	U/min. 0,75 sl./min tr./min	6,3 kW
	12,0 / 43,0 / 85,0 m/min	3,0 kW
	25,0 m/min	2 x 4,0 kW (120 HC) 2 x 7,5 kW (256 HC) 2 x 5,5 kW (185 HC, 170 HC)
	kVA	22,0 kW 22,0 kW, FU 40,0 30,0

	Stufe / Step / Cran Marcia / Grado Velocidade		kg	m/min
	22,0 / 18,0 / 4,0 kW, KL WIW 220 KY 006			
1		3000		3000 7,2
2		3000		3000 30,0
3		1500		1400 70,0
62,0 m LS- Trommel				
4 Lagen Layers Couches strati camadas capas				
1		6000		3100 3,6
2		6000		6000 15,0
3		3100		3100 35,0
22,0 kW, FU WIW 230 KY 002				
1		3000		3000 3,6
2		3000		3000 36,0
3		2400		2300 44,0
4		1500		1400 70,0
78,0 m LS- Trommel				
5 Lagen Layers Couches strati camadas capas				
1		6000		6000 1,8
2		6000		6000 18,0
3		4800		4800 22,0
4		3100		3100 35,0

	100 LC		185 HC		256 HC	
12	-	-	-	-	-	-
11	44,5* FEM	44,4* FEM	-	-	55,7*	60,4*
10	40,5* DIN	40,4* DIN	51,6*	56,2*	51,6	56,3
9	36,5	36,4	47,5	52,1	47,4	52,1
8	32,5	32,4	43,3	47,9	43,3	48,0
7	28,5	28,4	39,2	43,8	39,2	43,9
6	24,5	24,4	35,1	39,7	35,0	39,7
5	20,5	20,4	30,9	35,5	30,9	35,6
4	16,5	16,4	26,8	31,4	26,7	31,4
3	12,5	12,4	22,6	27,2	22,6	27,3
2	8,5	8,4	18,5	23,1	18,5	23,2
1	4,5	4,4	14,4	19,0	14,3	19,0
0	m -	m -	m 10,2	14,8	m 10,2	14,9
	4,5 m	4,5 m	6,0 m	6,0 m	6,0 m	6,0 m
			r = 12,0 m	r = 12,5 m		
					12,4 m	12,4 m
					7,8 m	7,8 m
					8,0 m	8,0 m
					r = 18,0 m	r = 18,0 m

# Ausladung und Tragfähigkeit

Radius and capacity / Portée et charge / Sbraccio e portata / Alcances y cargas / Alcance e capacidade de carga

m	r	m/kg	m/kg															
			16,0	18,0	20,0	22,0	25,0	28,0	30,0	32,0	35,0	38,0	40,0	42,0	45,0	48,0	50,0	52,5
52,5	(r = 54,0)	2,4 - 27,9 3000				3000	3000	2990	2760	2560	2310	2090	1970	1850	1700	1570	1490	1400
50,0	(r = 51,5)	2,4 - 31,6 3000				3000	3000	3000	3000	2960	2670	2430	2290	2160	1990	1840	1750	
45,0	(r = 46,5)	2,4 - 33,1 3000				3000	3000	3000	3000	3000	2820	2560	2410	2280	2100			
40,0	(r = 41,5)	2,4 - 34,7 3000				3000	3000	3000	3000	3000	2970	2710	2550					
35,0	(r = 36,5)	2,4 - 35,0 3000				3000	3000	3000	3000	3000	3000							
30,0	(r = 31,5)	2,4 - 30,0 3000				3000	3000	3000	3000									
25,0	(r = 26,5)	2,4 - 25,0 3000				3000	3000											

m	r	m/kg		m/kg															
		2,4 - 26,9 3000	2,4 - 14,7 6000	16,0	18,0	20,0	22,0	25,0	28,0	30,0	32,0	35,0	38,0	40,0	42,0	45,0	48,0	50,0	52,5
52,5	(r = 54,0)	2,4 - 26,9 3000	2,4 - 14,7 6000	5450	4780	4240	3800	3270	2860	2630	2430	2170	1950	1830	1710	1560	1420	1340	1250
50,0	(r = 51,5)	2,4 - 30,5 3000	2,4 - 16,6 6000	6000	5490	4880	4390	3790	3320	3060	2830	2540	2290	2150	2020	1840	1690	1600	
45,0	(r = 46,5)	2,4 - 31,8 3000	2,4 - 17,3 6000	6000	5760	5120	4600	3980	3490	3220	2980	2680	2420	2270	2130	1950			
40,0	(r = 41,5)	2,4 - 33,3 3000	2,4 - 18,1 6000	6000	6000	5390	4850	4190	3680	3400	3150	2830	2560	2400					
35,0	(r = 36,5)	2,4 - 35,0 3000	2,4 - 19,1 6000	6000	6000	5690	5120	4440	3900	3600	3340	3000							
30,0	(r = 31,5)	2,4 - 30,0 3000	2,4 - 20,0 6000	6000	6000	6000	5400	4680	4110	3800									
25,0	(r = 26,5)	2,4 - 25,0 3000	2,4 - 20,8 6000	6000	6000	6000	5650	4900											

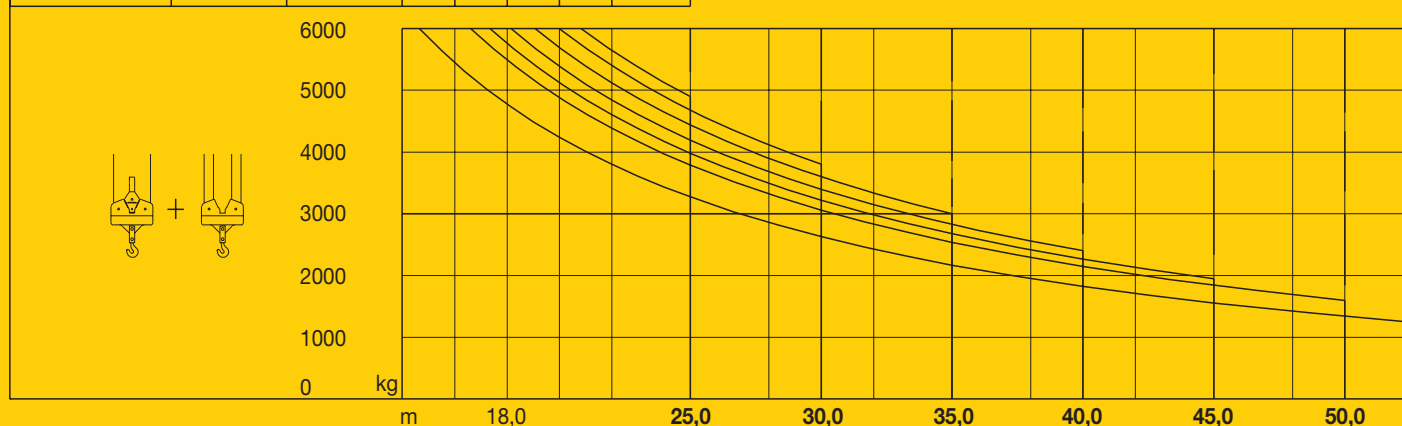

## Technische Daten

Technical data - Caractéristiques techniques

Caratteristiche tecniche - Características técnicas - Datos técnicos

# Kolli-Liste

Packing List / Liste de colisage / Lista dei colli  
Lista de contenido / Lista de embalagem







Montagegewichte: siehe Betriebsanweisung.  
Erection weights: see instruction manual.  
Poids de montage: voir manuel de service.  
Pesi di montaggio: vedasi le istruzioni sull'uso.  
Pesos de montagem: vejam-se as instruções p. uso.  
Peso para el montaje: según manual.

Kranoberteil		Upper part of crane / Partie supérieure de gru Parte superiore della gru / Parte superior grúa Parte superior do guindaste	L (m)	B (m)	H (m)	kg
Pos. Item Ref	Anz. Qty. Voce Qta. Cant. Cant.	Komplettkrankopf / One-piece machine deck / Tête de grue Testa completa della gru Módulo giratorio / Cabeça compl. de guindaste				
1	1		14,60			
			12,80	2,44	2,62	8800
2	1	Kabine mit Podest / Cabin with platform / Cabine avec plate-forme Cabina con piattaforma / Cabina con plataforma / Cabina com plataforma				
			4,20	1,35	2,20	950
3	1	Übergangsstück / Adapter section Tronçon de conversation / Spezzone collegamento / Tramo de adaptación Peça ligadora				
			120 HC 5,00 170 HC 2,41 185 HC 2,41 256 HC 2,41	2,20 2,50 2,70 2,70	2,30 2,30 2,40 2,40	2540 2750 3170 3170
4	1	Drehbühne kpl. / Slewing platform cpl. Ensemble mât cabine cpl. / Piattaforma girevole compl. / Conjunto plataforma de giro / Plataforma giratória compl.				
			2,05	1,75	2,45	3000
5	1	Turmspitze + Teilabspannung / Tower head section + first suspension bars / Porte-flèche + premiers tirants Cuspide + tiranti / Cabeza de torre + tirante de fijación Cabeça de torre + parte de acessórios de ancoragem				
			5,30	1,40	1,70	1200
6	1	Gegenausleger kpl. / Counter-jib cpl. Contre-flèche cpl. / Controfreccia Conjunto plataforma / Contra-lança compl.				
			L1 11,10	2,00	2,55	3450
7	1	Ausleger-Anlenkstück + Teilabspannung / Jib heel section + first suspension bars / Pied de flèche + premiers tirants / 1 Elemento freccia + tiranti parziale / Tramo pie de pluma + Tirante de fijación / Base articulada da lança + parte de acessórios de ancoragem				
			11,97	1,15	1,50	① 1600
8	1	Ausleger-Zwischenstück + Abspannung Intermediate jib section + suspension bars / Élément interm. de flèche + tirants / Elemento intermedi braccio + tiranti / Tramo intermedio de pluma + tirantes Peça suplementar de lança + acessórios de ancoragem				
			10,20 12,00 5,20 5,20 5,20	1,02 1,02 1,02 1,02 1,02	1,50 1,50 1,25 1,25 1,25	② 1250 ③ 1350 ④ 350 ⑤ 290 ⑥ 220
9	1	Ausleger-Kopfstück / Jib head Pointe de flèche / Punta freccia Cabeça de lança / Tramo punta de pluma				
			2,70 1,80	1,02 1,02	1,25 1,40	⑦ 120 ⑧ 125
<b>Turm</b>		<b>Tower / Mât / Torre Torre / Torre</b>				
10		Turmstück / Tower section Element de mât / Elemento di torre Torre / Torre				
			120 HC 2,50 120 HC 5,00 170 HC 4,14 185 HC 4,14 256 HC 4,14	1,80 1,80 1,90 2,30 2,30	1,80 1,80 1,90 2,30 2,30	1090 1830 1850 2240 2300
11		Turmstück lang / Long tower section Élément de mât long / Elemento di torre, lungo Tramo de torre largo / Peça de torre, comprida				
			120 HC 10,0	1,80	1,80	3425
12	1	Grundturmstück / Base tower section Mât de base / Elemento di torre base Tramo torre base / Peça de base de torre				
			120 HC 6,85 120 HC 10,0 170 HC 9,60 185 HC 8,85 256 HC 8,85 (12,42)	1,80 1,80 1,90 2,30 2,30 (2,30)	1,80 1,80 1,90 2,30 2,30 (2,30)	2610 3530 4350 4280 4830 (7940)
<b>Klettereinrichtung</b>		<b>Climbing equipment / Equipement de télescope / Attrezzatura per allungamento della gru Equipo de trepado / Acesórios p. subida no edifício</b>				
13	1	Führungsstück kpl. / Guide section cpl. Cage télescopique cpl. / Gabbia de sopraelevazione compl. / Peça de guia compl. / Torre de montaje completa				
			120 HC 6,45 120 HC 9,60 170 HC 9,04 185 HC 8,39 256 HC 8,39	2,10 2,10 2,31 2,80 2,80	2,42 2,42 2,28 2,50 2,50	2660 4410 4750 4070 4070
14	1	Hydraulikanlage, Stütz- und Klettertraverse / Hydraulic unit, supporting and climbing cross members / Système hydraulique avec traverses d'appui et de télescope / Sistema idraulico, traversa di appoggio e allungamento gru / Instalação hidráulica, travessa de apoio e subida Sistema hidráulico con traviesa de apoyo y trepado				
			120 HC 2,87 170 HC 2,30 185 HC 2,30 256 HC 2,30	2,12 1,10 1,10 1,10	1,06 1,00 1,00 1,00	1000 1100 1100 1100
<b>Unterwagen</b>		<b>Undercarriage / Châssis / Carro della gru Carro con mástil / Carro de guindaste</b>				
15	2	Fahrschemel mit Antrieb / Rail bogie with drive / Bogie moteur / Telaio con gruppo propulsore / Quadro sem grupo de propulsão / Caja rodillo motriz				
			120 HC 1,38 170 HC 1,46 185 HC 1,46 256 HC 1,63 (1,46)	0,88 0,84 0,84 0,92 (0,84)	0,87 0,87 0,87 0,95 (0,87)	900 920 920 1690 (920)
16	2	Fahrschemel ohne Antrieb / Rail bogie without drive / Bogie fou / Telaio senza gruppo propulsore / Quadro con grupo de propulsão / Caja rodillo conducido				
			120 HC 1,17 170 HC 1,15 185 HC 1,15 256 HC 1,37 (1,15)	0,60 0,60 0,60 0,62 (0,60)	0,87 0,87 0,87 0,95 (0,87)	860 880 880 1340 (880)
17	1	Tragholm lang / Long support arm Longeron long / Longherone lungo Brazo largo soporte / Travessa comprida				
			120 HC 7,12 170 HC 7,15 185 HC 9,10 256 HC 9,10 (11,95)	0,78 0,80 0,82 0,80 (0,82)	0,65 0,70 0,74 0,80 (0,80)	950 1070 1350 1650 (2200)



Pos. Anz.  
Item Qty.  
Rep Qté.  
Voce Qta.  
Pos. Cant.  
Ref. Cant.

Einzelgewichte. / Single weights. / Poids individuels.  
Pesi di componenti.  
Pesos de peças componentes.  
Pesos unitarios.

					L (m)	B (m)	H (m)	kg	
18	2	<b>Tragholm kurz</b> / Short support arm Longeron court / Longherone corto Brazo corto soporte / Travessa curta		120 HC	3,45	0,56	0,55	408	
				170 HC	3,45	0,60	0,70	500	
				185 HC	4,41	0,62	0,71	615	
				256 HC	4,45 (5,85)	0,77 (0,65)	0,77 (0,77)	800 (1035)	
19	2 + 2	<b>Randträger</b> / Border support Traverse / Supporti base Traviesa / Apoio de bordo		120 HC	4,02	0,35	0,12	95	
				170 HC	4,08 – 4,30	0,16 – 0,33	0,11 – 0,14	80 – 200	
				185 HC	5,48 – 5,46	0,11 – 0,17	0,16 – 0,38	118 – 454	
				256 HC	5,46 – 5,40	0,11 – 0,18	0,16 – 0,38	175 – 525	
					(7,52 – 7,46)	(0,1 – 0,17)	(0,1 – 0,38)	(366 – 912)	
20	4	<b>Stützholm</b> / Support strut Hauban de châssis / Correnti di appoggio Tirante vertical / Travessa de apoio		120 HC	3,78	0,15	0,22	200	
				170 HC	3,53	0,25	0,17	240	
				185 HC	4,23	0,17	0,25	275	
				256 HC	4,14 (6,55)	0,18 (0,22)	0,25 (0,25)	320 (600)	
21	1	<b>Unterwagen-Turmstück</b> / Undercarriage tower section / Mât de châssis / Elemento di torre del carro / Tramo de carro Peça de torre do chassis		120 HC	3,50	2,06	2,06	1320	
				170 HC	3,30	2,15	2,15	2000	
				185 HC	3,73	2,52	2,52	1950	
				256 HC	3,73 (6,70)	2,62 (2,53)	2,62 (2,53)	2250 (3800)	
22	2	<b>Fundamentkreuz mit Spindeln, Tragholm lang</b> / Cruciform base with outrigger jacks, long support arm / Châssis en croix avec vérins, longeron long / Base incrociata con aste, longherone lungo / Tramo largo base cruciforme, con husillos Base cruciforme com árvores, travessa comprida		91 EC	4,6 m	7,00	0,90	0,90	3000
					3,8 m	5,90	0,90	0,90	2700
23	2	<b>Fundamentkreuz fahrbar, Tragholm lang</b> / Cruciform rail going, long support arm / Châssis en croix roulant, longeron long / Base incrociata mobile, longherone lungo / Brazo soporte largo de base cruciforme para traslación sobre vía Base cruciforme móvil, travessa comprida		91 EC	4,6 m	7,00	0,90	0,90	2800
					3,8 m	5,90	0,90	0,90	2500
24	4	<b>Fundamentkreuz fahrbar, Randträger</b> / Cruciform rail going, border support / Châssis en croix roulant, traverse Base incrociata mobile, travessa / Traviesa de base cruciforme / Base cruciforme móvil, apoio de bordo (Fahrwerke wie Pos. 15 und 16) / (Travel gears as under item 15 and 16) / (Mécanismes de translation comme pos. 15 et 16) / (Gruppi propulsori marcia come da voce 15 e 16) / (Mecanismos de traslación como Pos. 15 y 16) / (Grupos de propulsão de marcha: igual a ref. 15 et 16)		91 EC	4,6 m	3,90	0,60	0,20	185
					3,8 m	3,00	0,60	0,20	155
25	1	<b>Kiste mit Kleinteilen</b> / Crate with small parts Caisse contenant des accessoires / Cassa con accessori Caja con accesorios / Caixa de acessórios		120 HC					
				170 HC					
				185 HC	2,00	1,00	1,00	2000	
				256 HC					

\*( ) **Angaben in Klammern gelten für 8 m-Unterwagen.** / The data in brackets are valid for an undercarriage of 8 m. / Les données techniques indiquées entre parenthèses sont valables pour un châssis de 8 m. / Caratteristiche in (...) valgono per carro di 8 m. / Los datos entre paréntesis son válidos para carro de 8 m. Características em (...) válidas pelo chassis de 8 m.

121 P – 4339 H1 B3 DIN 15018 • BGL 2125-0100 / FEM (Section 1) Krangruppe A3 • 03.01 / 6

Konstruktionsänderungen vorbehalten! / Subject to alterations!  
Sous réserves de modifications! / Si fa riserva di modifiche!  
Salvo modificação da construção! / ¡Sujeto a modificaciones!

Printed in Germany.



**LIEBHERR-WERK BIBERACH GMBH, Postfach 1663, D-88396 Biberach an der Riß**  
☎ (0 73 51) 41-0, Fax (0 73 51) 41 22 25, www.lbc.liebherr.de, E-Mail: info@lbc.liebherr.com

Courtesy of Crane.Market